











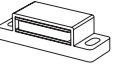

Assembly instructions / Directives d'assemblage / Instrucciones de ensamble / Anleitungen zum zusammenbau:

Parts List / Lista de Componentes / Liste des pieces / Teileliste:		Qty. Cant. / Qté / Menge
(A)	Right Side Panel Panel Lateral Derecho Panneau du côté droit Rechte Seitenwand	1
(B)	Left Side Panel Panel Lateral Izquierdo Panneau du côté gauche Linke Seitenwand	1
(C)	Base Repisa inferior Tablette de base Boden-regalplatte	1
(D)	Back Panel Panel Posterior Panneau arrière Rückenwand	1
(E)	Top Panel Panel superior Panneau du dessus Deckplatte	1
(F)	Fixed Shelf Estante fijo Tablette fixe Befestigtes Regalbrett	1
(G)	Shelves Estantes Tablettes Regal	3
(H)	Glass door Puerta de vidrio Porte de verre Glastür	1
(I)	Bottom Panel Panel Inferior Panneau de bas Bodenplatte	1

<p>Tools needed/ not included Herramientas requeridas/ no incluidas Outils requis/ non fournis Benötigtes Werkzeug/ liegt nicht bei</p> <p>* Phillips Screwdriver Desarmador de estrella (Phillips) Tournevis Phillips Kreuzschlitzschraubenzieher</p> <p>* Pencil Lápiz Crayon Bleistift</p> <p>* Power Drill Taladro eléctrico Perceuse électrique Elektrobohrer</p>
--

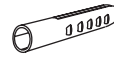
Hardware / Herrajes / Matériel / Eisenwaren:		Qty. Cant. / Qté / Menge
(1)		12
(2)		12
(3)		12
(4)		12
(5)		6
(6)		2
(6a)		1
(7)		1
(8)		1
(9)		1
(10)		1
(11)		1
(12)		2
(13)		2

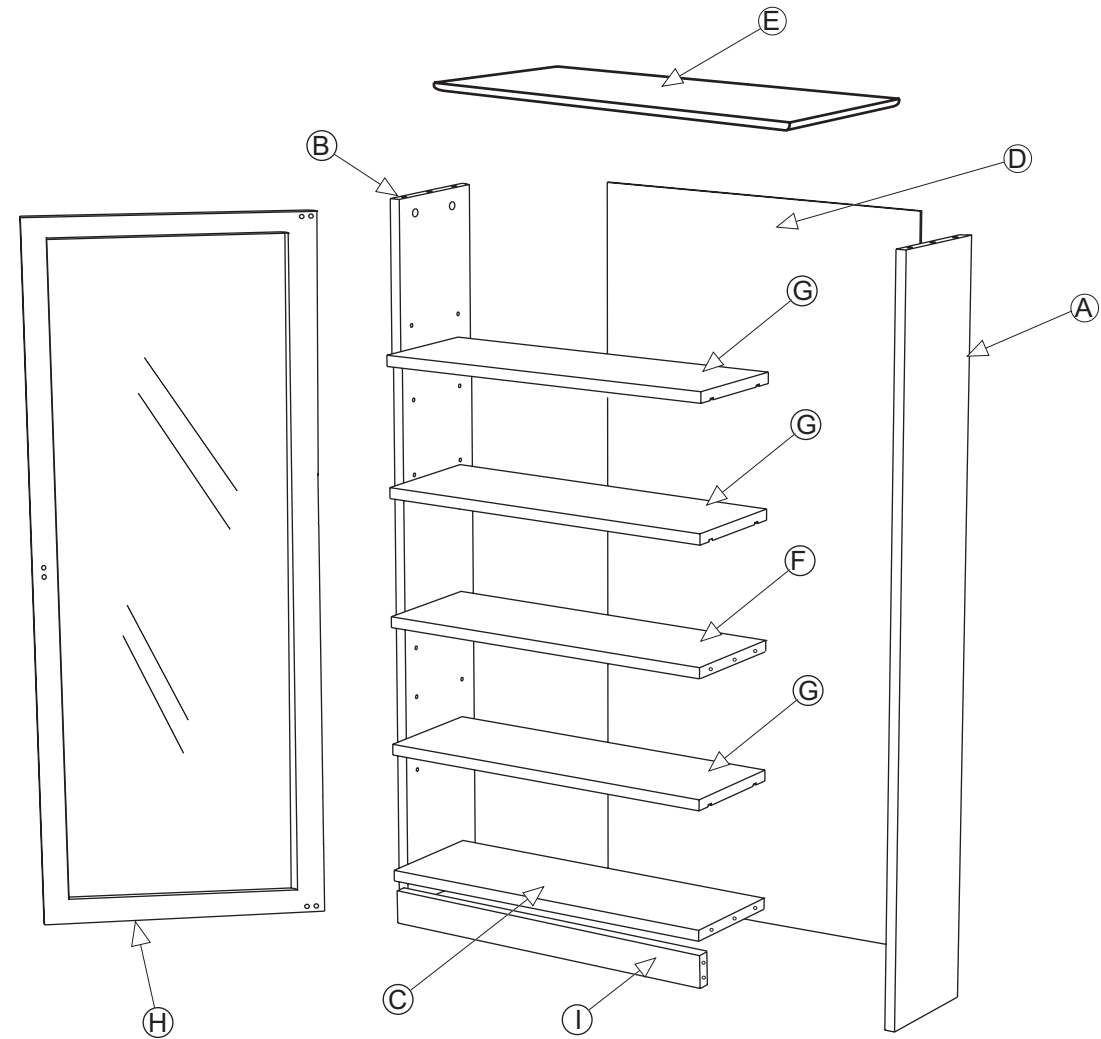

ATLANTIC®

© 2005 Atlantic Inc. Santa Fe Springs, CA, U.S.A.
U.S. AND OTHER FOREIGN PATENTS PENDING
ALL RIGHTS RESERVED
www.atlantic-inc.com

MADE IN CHINA

Patentes de los EUA y países extranjeros en trámite /
Brevets en cours pour les États-Unis et autres pays /
U.S. und andere ausländische Patente sind hängig

Derechos Reservados / Tous droits réservés /
Alle Rechte vorbehalten

Hecho en China / Fabriqué en Chine /
Hergestellt in China



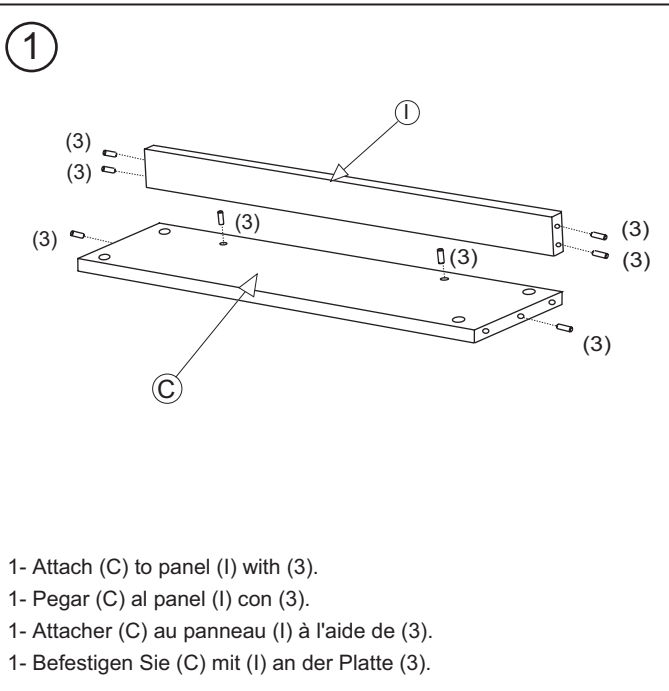

- 1- Attach (C) to panel (I) with (3).
- 1- Pegar (C) al panel (I) con (3).
- 1- Attacher (C) au panneau (I) à l'aide de (3).
- 1- Befestigen Sie (C) mit (I) an der Platte (3).

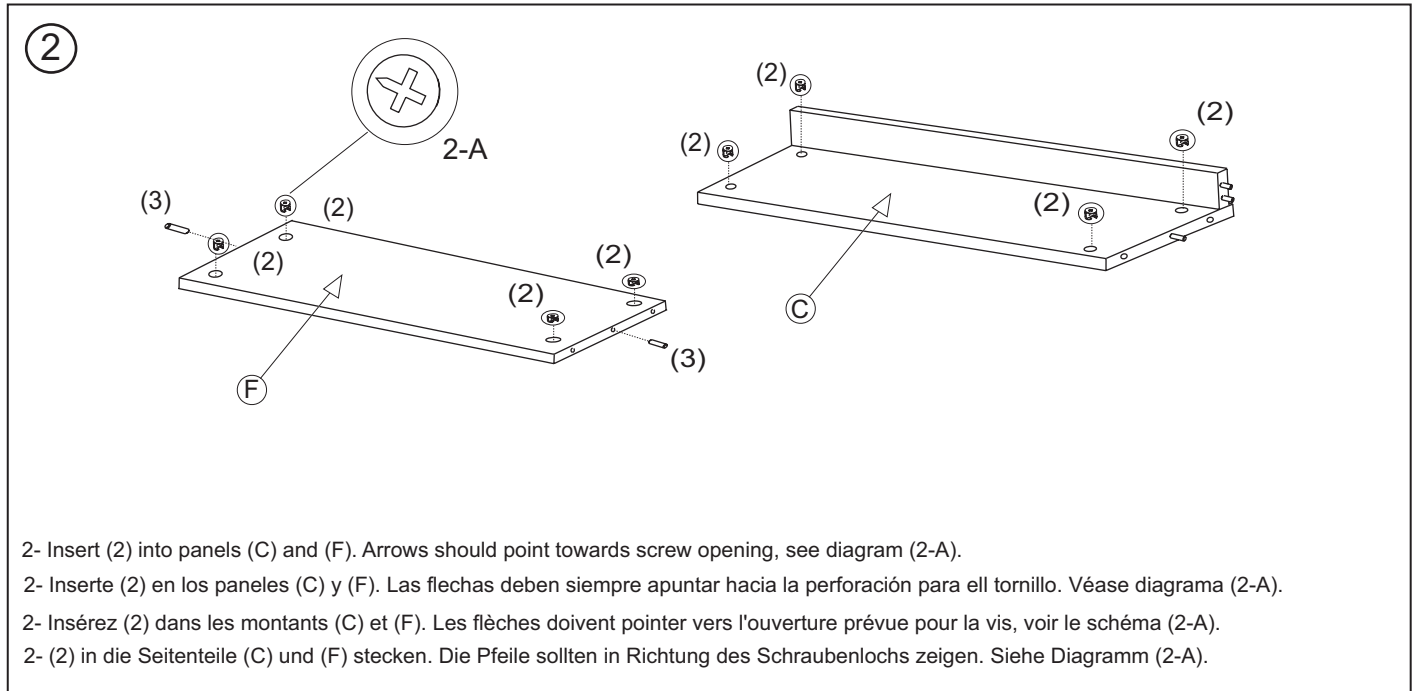

- 2- Insert (2) into panels (C) and (F). Arrows should point towards screw opening, see diagram (2-A).
- 2- Inserte (2) en los paneles (C) y (F). Las flechas deben siempre apuntar hacia la perforación para el tornillo. Véase diagrama (2-A).
- 2- Insérez (2) dans les montants (C) et (F). Les flèches doivent pointer vers l'ouverture prévue pour la vis, voir le schéma (2-A).
- 2- (2) in die Seitenteile (C) und (F) stecken. Die Pfeile sollten in Richtung des Schraubenlochs zeigen. Siehe Diagramm (2-A).

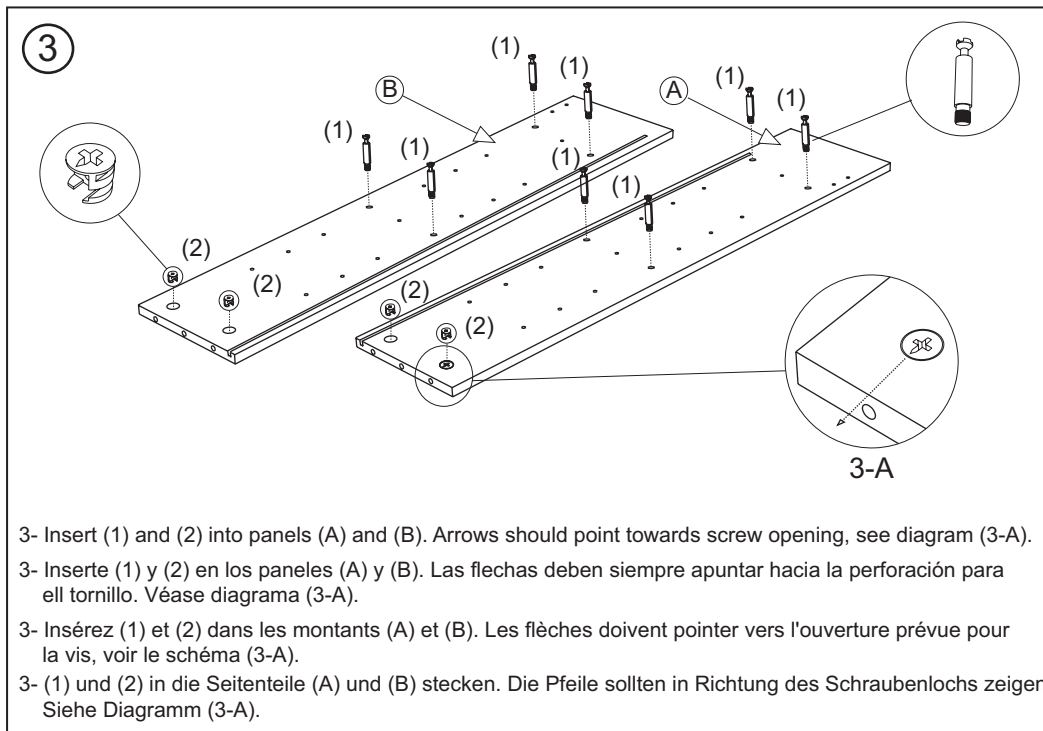

- 3- Insert (1) and (2) into panels (A) and (B). Arrows should point towards screw opening, see diagram (3-A).
- 3- Inserte (1) y (2) en los paneles (A) y (B). Las flechas deben siempre apuntar hacia la perforación para el tornillo. Véase diagrama (3-A).
- 3- Insérez (1) et (2) dans les montants (A) et (B). Les flèches doivent pointer vers l'ouverture prévue pour la vis, voir le schéma (3-A).
- 3- (1) und (2) in die Seitenteile (A) und (B) stecken. Die Pfeile sollten in Richtung des Schraubenlochs zeigen. Siehe Diagramm (3-A).

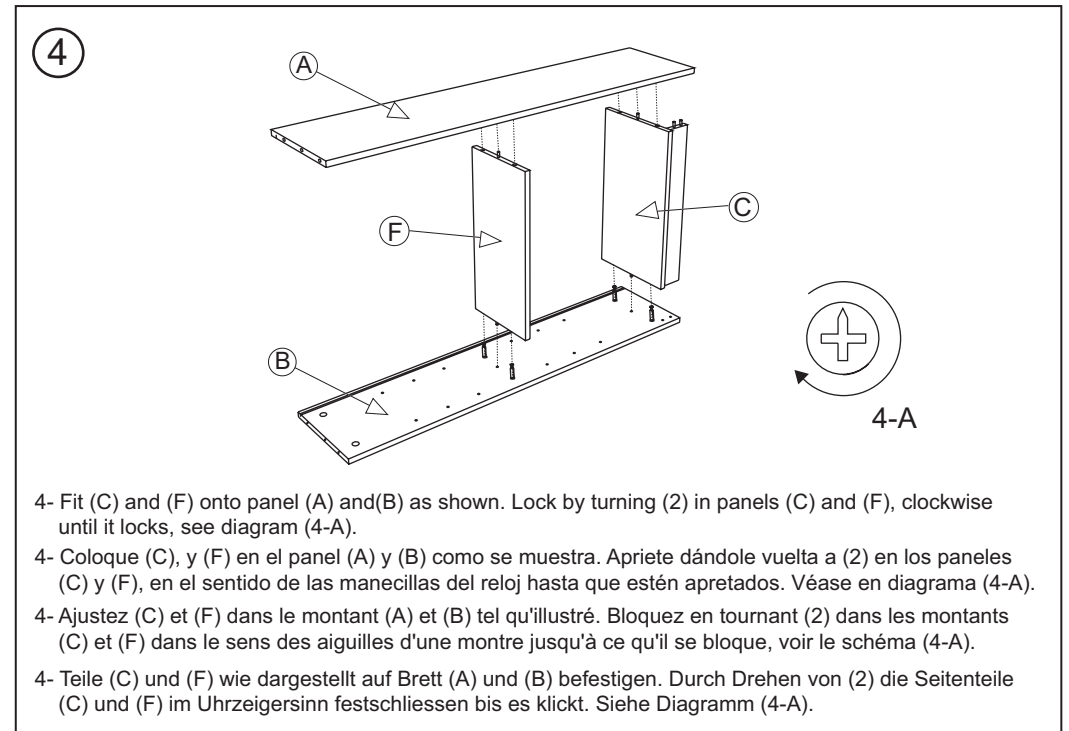

- 4- Fit (C) and (F) onto panel (A) and (B) as shown. Lock by turning (2) in panels (C) and (F), clockwise until it locks, see diagram (4-A).
- 4- Coloque (C), y (F) en el panel (A) y (B) como se muestra. Apriete dándole vuelta a (2) en los paneles (C) y (F), en el sentido de las manecillas del reloj hasta que estén apretados. Véase en diagrama (4-A).
- 4- Ajustez (C) et (F) dans le montant (A) et (B) tel qu'illustré. Bloquez en tournant (2) dans les montants (C) et (F) dans le sens des aiguilles d'une montre jusqu'à ce qu'il se bloque, voir le schéma (4-A).
- 4- Teile (C) und (F) wie dargestellt auf Brett (A) und (B) befestigen. Durch Drehen von (2) die Seitenteile (C) und (F) im Uhrzeigersinn festschliessen bis es klickt. Siehe Diagramm (4-A).

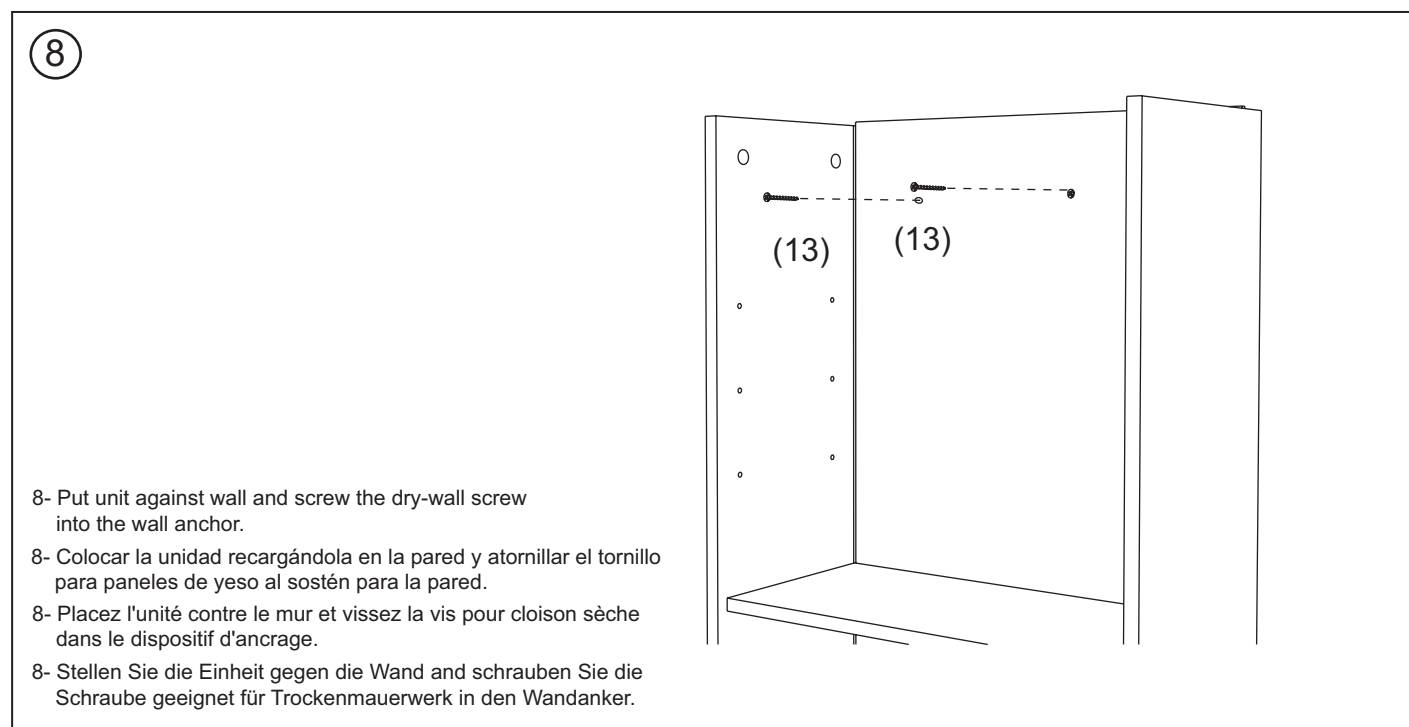
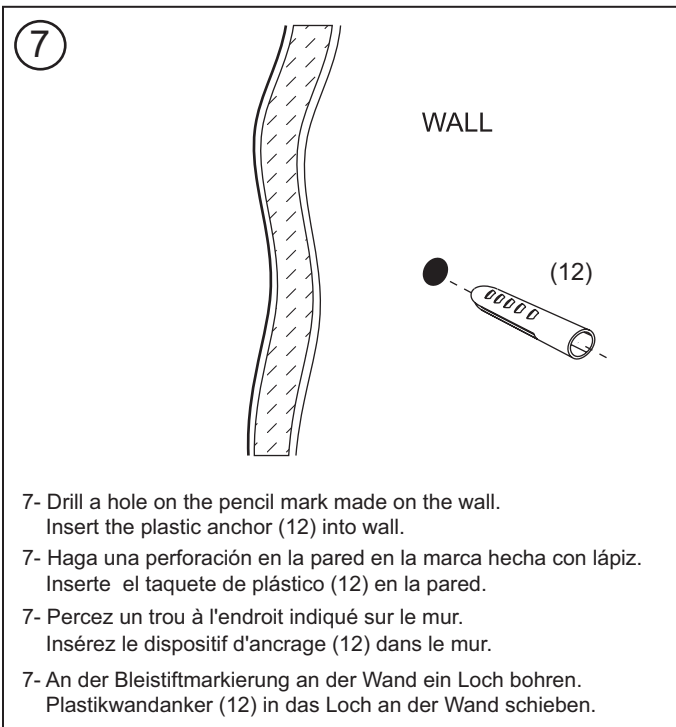
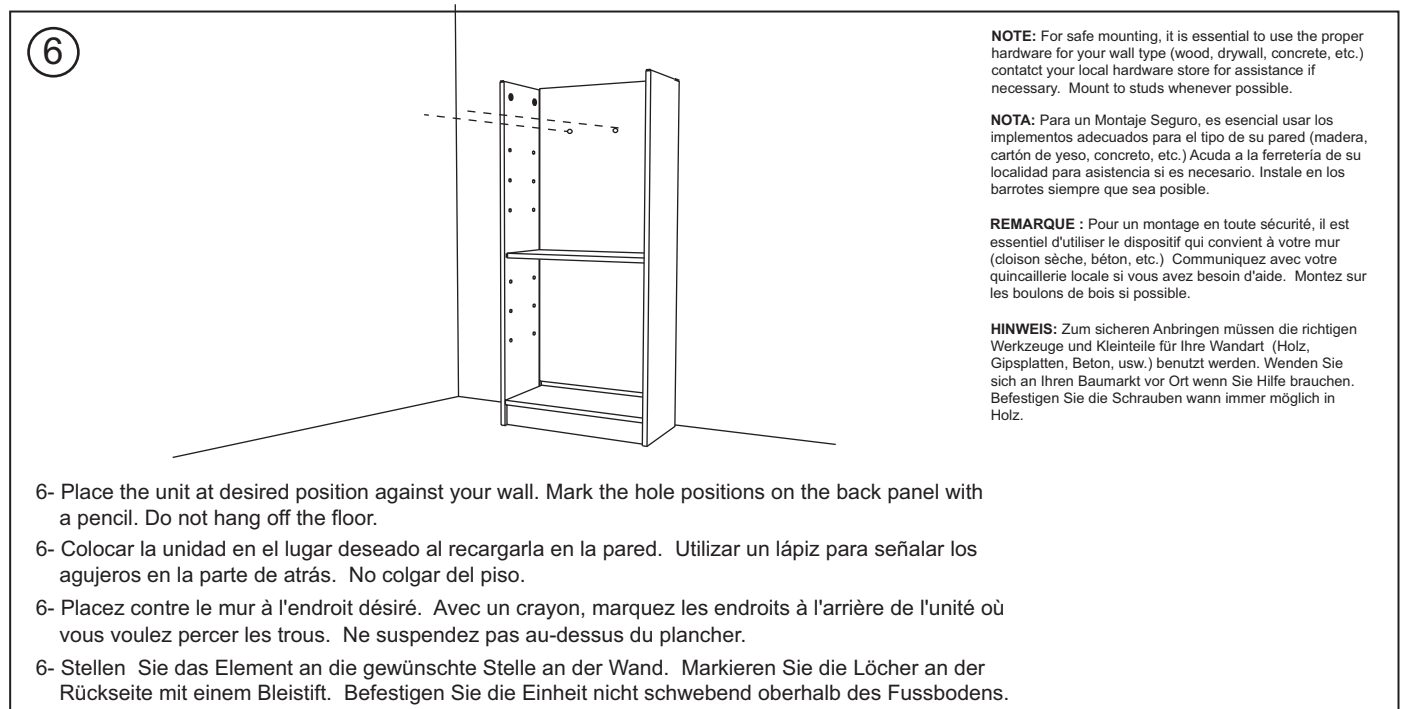
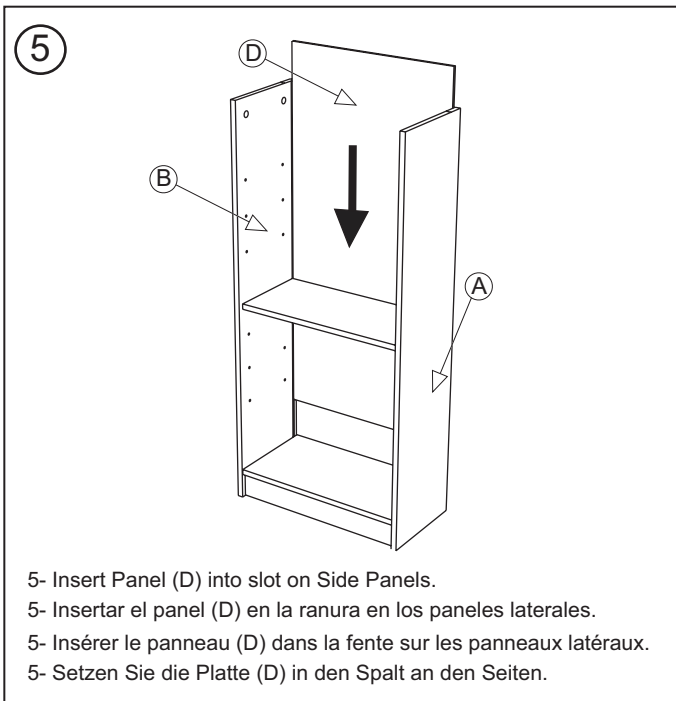

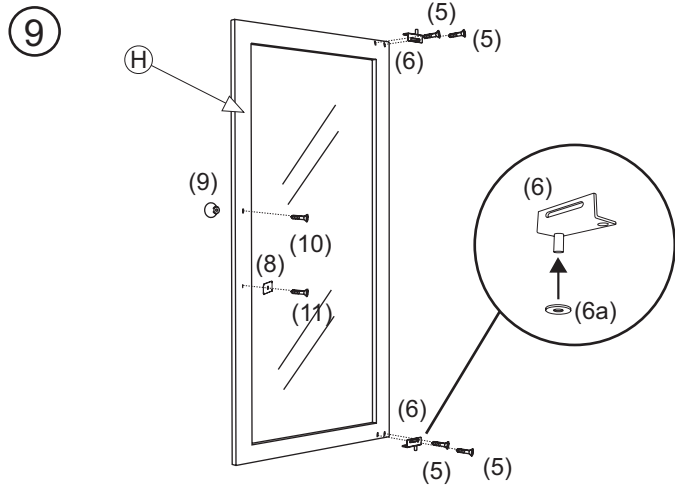

- 9- Install door hardware (6), (6a), (8) and (9), with screws (5), (11) and (10).
 9- Instalar la herramienta de la puerta (6), (6a), (8) y (9) con los tornillos (5), (11) y (10).
 9- Installez les ferrures de porte (6), (6a), (8) et (9) à l'aide des vis (5), (11) et (10).
 9- Installieren Sie die Türeisenwaren (6), (8) und (9) mit den Schrauben (5), (11) und (10).

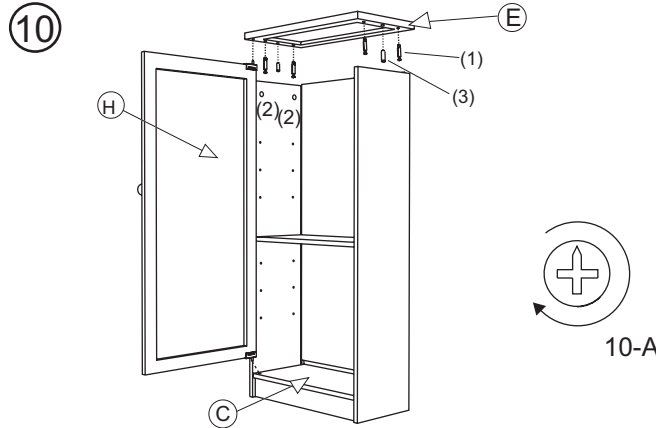

- 10- Attach bottom hinge (6) on door to base (C). Place (E) on top and fasten by turning (2), see diagram (10-A).
 10- Juntar la bisagra inferior (6) de la puerta a la base (C). Colocar (E) arriba y juntarlo al dar vuelta a (2). Véase la gráfica (10-A).
 10- Fixez la charnière du bas (6) de la porte sur la base (C) Placez (E) sur le dessus et vissez en tournant (2), voir le schéma (10-A).
 10- Befestigen Sie das untere Scharnier (6) der Tür an der Grundfläche (C). Setzen Sie (E) oben drauf und befestigen Sie es, indem Sie (2) festziehen. Bitte sehen Sie Diagramm (10-A) ein.

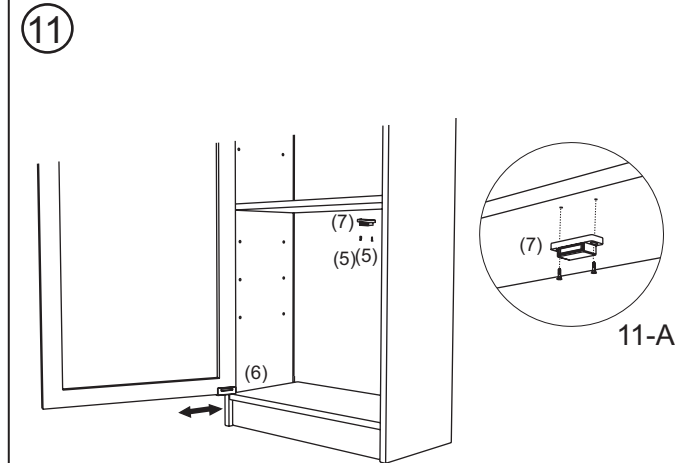

- 11- Install (7) with (5) and adjust door hinges (6).
 11- Instale (7) con (5) y ajuste las bisagras de la puerta (6).
 11- Installez (7) à l'aide de (5) et ajustez les charnières (6).
 11- Installieren Sie (7) mit (5) und sichern Sie die Türscharniere (6).

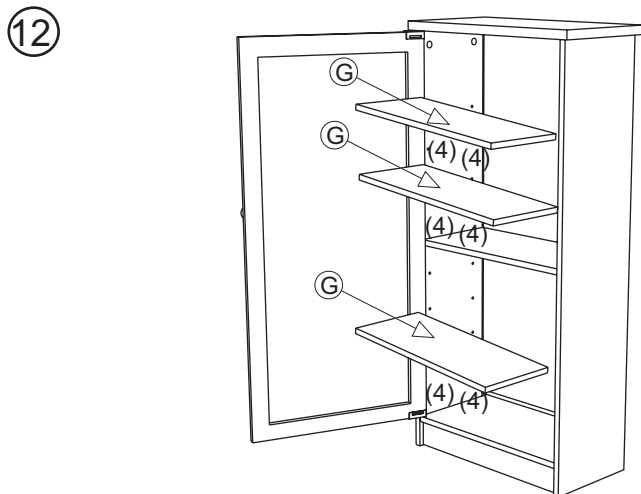

- 12- Insert pins (4) at desired heights. Place shelves (G) on pins (4).
 12- Inserte los pines (4) a la altura deseada. Coloque los estantes (G) sobre los pines (4).
 12- Insérez les taquets (4) à la hauteur désirée. Placez les rayons (G) sur les taquets (4).
 12- Die Stifte (4) in der gewünschten Höhe in die Löcher stecken. Regale (G) auf die Stifte (4) auflegen.



ATLANTIC®

©2005 Atlantic Inc.
 Santa Fe Springs, CA, U.S.A.

U.S. AND OTHER FOREIGN PATENTS PENDING
 Patentes de los EUA y países extranjeros en trámite
 Brevets en cours pour les États-Unis et autres pays
 U.S. und andere ausländische Patente sind hängig

ALL RIGHTS RESERVED
 Derechos Reservados / Tous droits réservés /
 Alle Rechte vorbehalten

www.atlantic-inc.com

MADE IN CHINA

Hecho en China / Fabriqué en Chine /
 Hergestellt in China

