

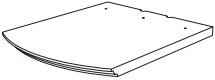













Assembly Instructions / Directives d'assemblage / Instrucciones / Anleitungen zum Zusammenbau:

QTY Cant. / Qté / Menge	PARTS LIST Lista de Componentes / Liste des pieces / Teileliste:	
2		A
2		B
2		C
2		D
8		E
4		(1)
2		(2)
2		(3)
2		(4)
2		(5-a)
2		(5-b)
2		(6)
2		(7)
4		(8)
4		(9)

*Tools not included.
*Non fournis.
*No incluidas.
*Liegt nicht bei.

Tools needed / Outils requis
Herramientas requeridas /
Benötigtes Werkzeug

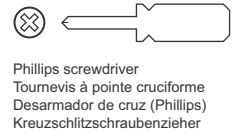

1

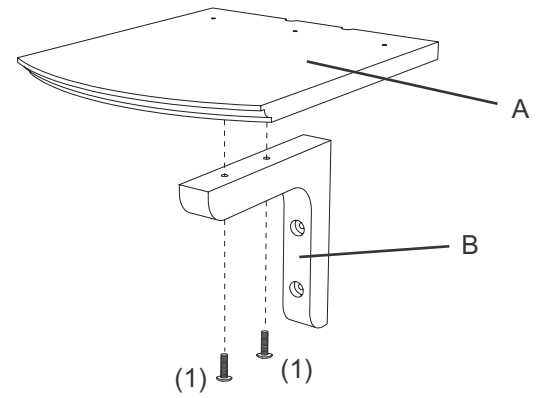
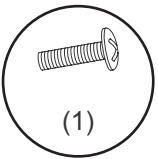

2

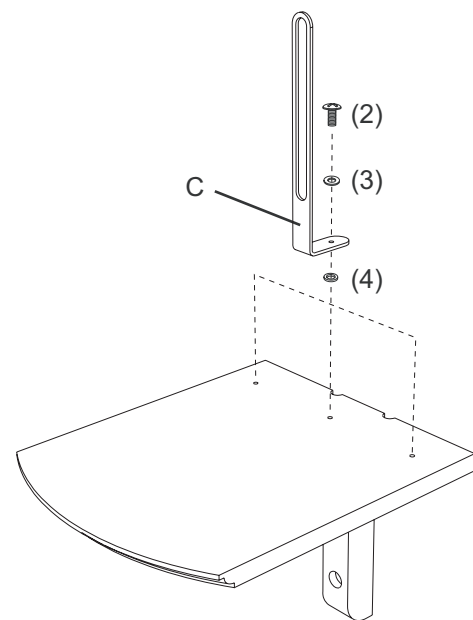
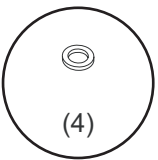
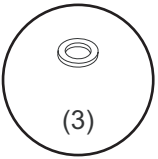
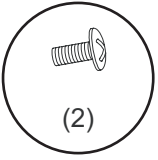

or * ou * o * oder

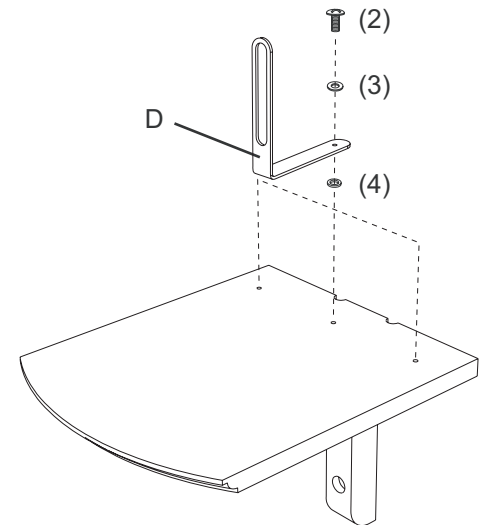

Multiple Configurations
 Configuración Múltiple
 Configuration multiple
 Mehrfache Konfiguration

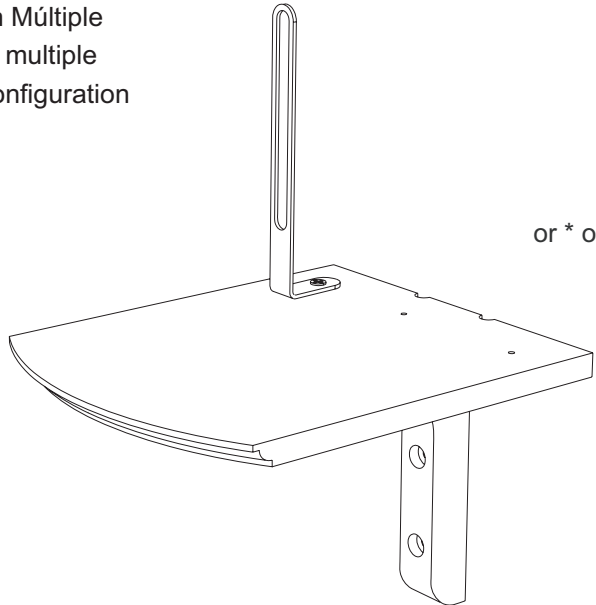

or * ou * o * oder

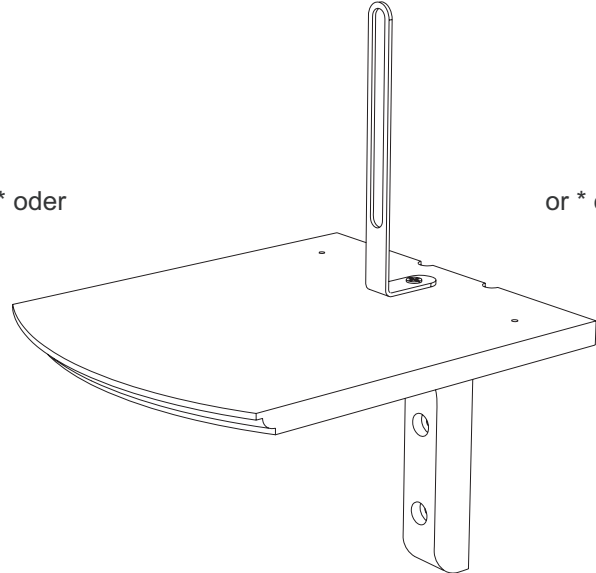

or * ou * o * oder

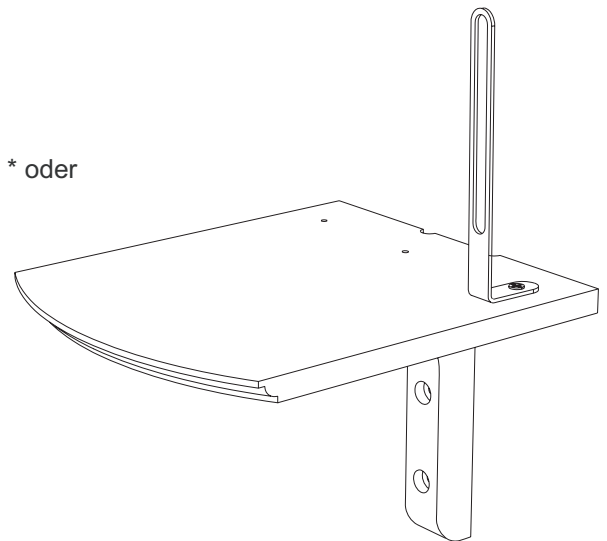

3

**Safety Wall Mount: / Montaje en Pared con Protección: /
 Fixation murale sécuritaire : / Sichere Wandbefestigung:**

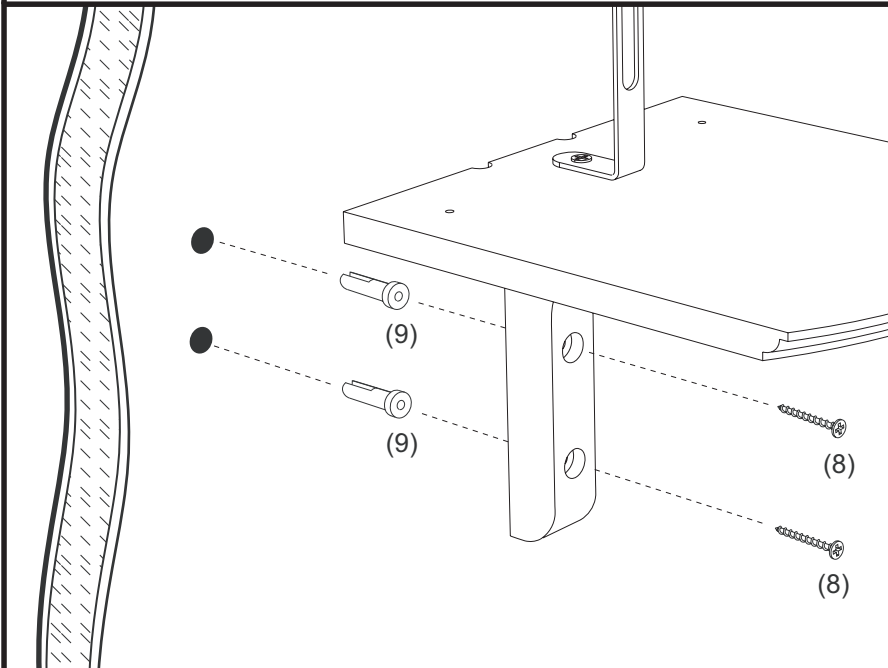

Parts List:
 Lista de Componentes / Liste des pièces / Teilleiste:

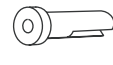
4		Plastic wall anchor. Taquete de plástico para pared Dispositif d'ancrage au mur en plastique Wandanker aus Kunststoff
4		Dry-wall screw Tornillo para pared de cartón de yeso Vis pour cloison sèche Gipsplattenschraube

Tools Needed: *TOOLS NOT PROVIDED.
Herramientas Necesarias: *NO SE INCLUYEN HERRAMIENTAS
Outils requis : *OUTILS NON FOURNIS
Benötigte Werkzeuge: *WERKZEUGE LIEGEN NICHT BEI

- * Pencil
Lápiz
Crayon
Bleistift
- * Power drill
Taladro eléctrico
Perceuse électrique
Elektrobohrer
- * Phillips screwdriver
Desarmador de estrella (Phillips)
Tournevis Phillips
Kreuzschlitzschraubenzieher

**Mounting Instructions:
 Intrucciones de Montaje / Directives de montage /
 Anleitung zur Befestigung:**

1. Place unit at the desired position on the wall. Mark the hole positions on the wall with a pencil.
 1. Colocar la unidad en el lugar deseado al recargarla en la pared. Marque la posición de la perforación en la pared con lápiz.
 1. Placez contre le mur à l'endroit désiré. Faites une marque avec votre crayon pour indiquer où vous percerez le trou.
 1. Stellen Sie das Element an die gewünschte Stelle an der Wand. Loch am Winkeleisen mit einem Bleistift an der Wand markieren.
2. Drill a hole on the pencil mark made on the wall. Insert the plastic anchor (9) into wall.
 2. Haga una perforación en la pared en la marca hecha con lápiz. Inserte el taquete de plástico (9) en la pared.
 2. Percez un trou à l'endroit indiqué sur le mur. Insérez le dispositif d'ancrage (9) dans le mur.
 2. An der Bleistiftmarkierung an der Wand ein Loch bohren. Plastikwandanker (9) in das Loch an der Wand schieben.
3. Put unit against wall and screw the dry-wall screw into the wall anchor.
 3. Colocar la unidad recargándola en la pared y atornillar el tornillo para paneles de yeso al sostén para la pared.
 3. Placez l'unité contre le mur et vissez la vis pour cloison sèche dans le dispositif d'ancrage.
 3. Stellen Sie die Einheit gegen die Wand and schrauben Sie die Schraube geeignet für Trockenmauerwerk in den Wandanker.

4

Speaker wire management
Manejo de alambre de bocina
Installation des fils de haut-parleurs
Handhabung des Lautsprecherkabels

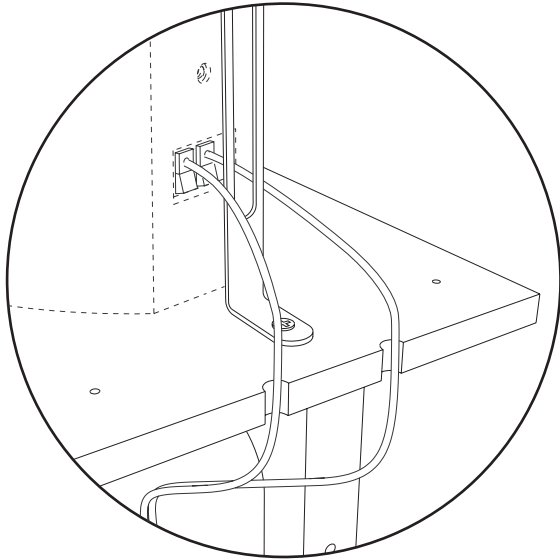

5

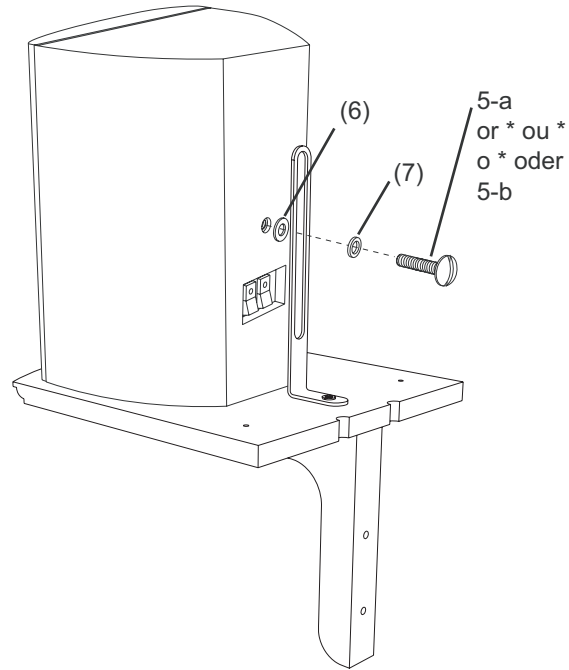
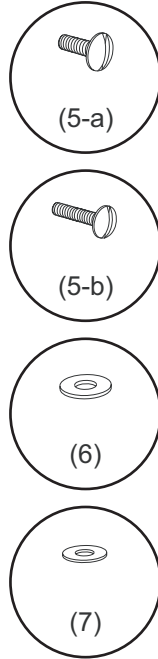

6

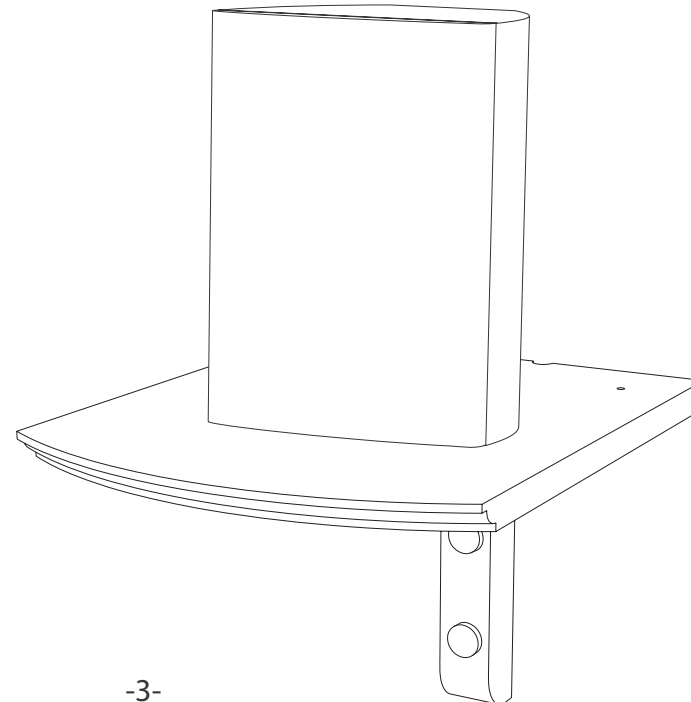
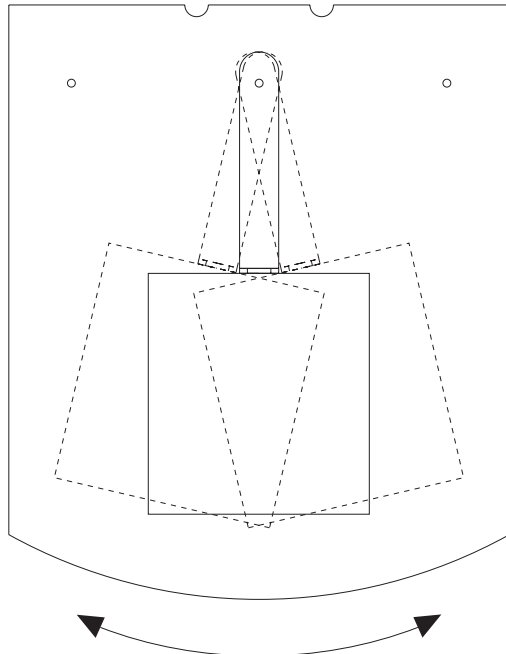
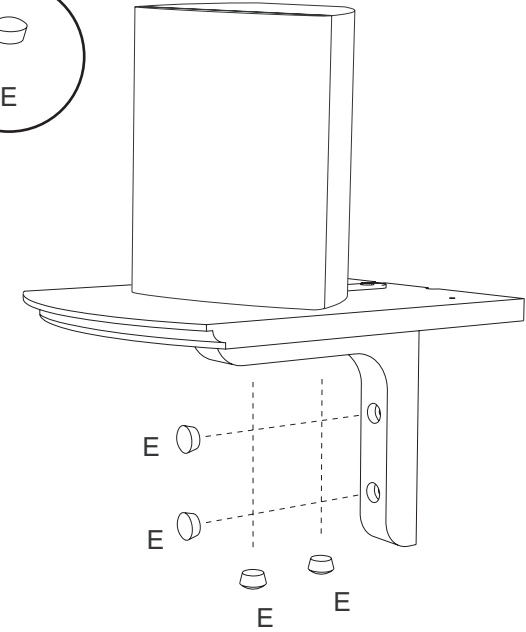
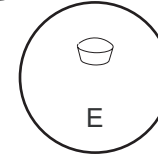

ATLANTIC®

©2005 Atlantic Inc.
Santa Fe Springs, CA, U.S.A.

U.S. AND OTHER FOREIGN PATENTS PENDING
Patentes de los EUA y países extranjeros en trámite
Brevets en cours pour Etats Unis et autres pays étrangers
U.S. und andere ausländische Patente sind hängig

ALL RIGHTS RESERVED
Derechos Reservados / Tous droits réservés /
Alle Rechte vorbehalten

www.atlantic-inc.com
MADE IN CHINA

Hecho en China / Fabriqué en Chine /
Hergestellt in China

R 2.0 050707 #77335211, 77335212

