



(inside fold)

DISC Manager

Thank you for purchasing a Disc Manager. Please take time to get to know your Disc Manager and its many great benefits. Then fill your Disc Manager with your favorite discs.

Know your Disc Manager

- 1 Title sheet tray
- 2 Self-aligning slots - Allow you to easily roll the disc into the slot.
- 3 Disc-selector button - To select a disc, push down and slide the button to the disc number of your choice.
- 4 Title sheet - To access the title sheet, pull out the title sheet tray.
- 5 Disc-numbering pen - Use a permanent ink marker to number each disc so the storage slots and the title sheet match. Now you can easily return each disc to its number slot.

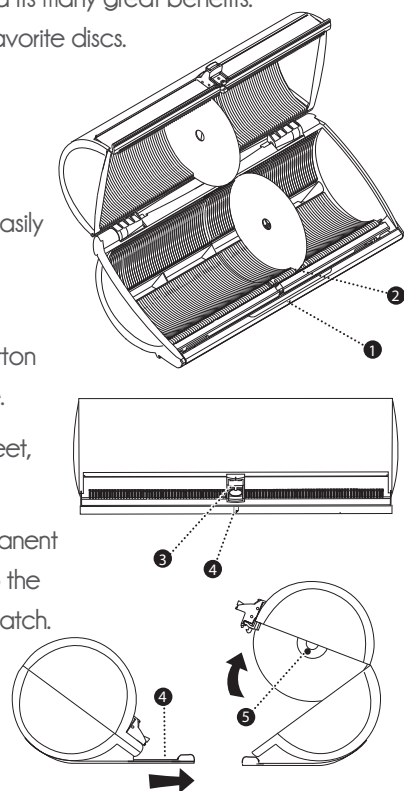

Disc Manager Instructions

A. **Organize your discs.** Choose one of these methods:

- 1) Visit www.mydiscgear.com to access our online service for cataloging and organizing your discs, and printing title sheets.
- 2) Remove title sheet from the plastic sleeves located in the sheet tray. Write your disc title directly on the title sheet.

B. **Access your title sheet.** Pull out the title sheet tray to view your title sheet. Now you may make your disc selection.

C. **Number your discs.** Use a permanent ink marker to number or reference your disc's slot number. Use an alpha-numeric system so you can organize multiple disc-storage units (Ex. A1, B1 , C1). *We recommend that you only write on the clear center ring on the front of the disc.*

D. **Fill your Disc Manager.** As you number each disc, place it in the corresponding slot number.

E. **Select your disc.** Press the disc-selector button and slide it to the desired numbered slot. Release, then lift the Disc Manager top shell and your desired disc is presented to you.

F. **Replace your discs.** Refer to the number on your disc, find the appropriate "self-aligning slot" and roll the disc back into location.

www.atlantic-inc.com

(outside fold)

5.5 in

4.5 in

Product Warranty: Atlantic Inc., warrants to the original purchaser that its products are free from defect in materials or workmanship. If after inspection, we find that the product was defective in materials or workmanship, we shall repair or replace the product at our discretion. This warranty does not cover accidental damage, misuse, improper care or alteration and excludes claims for incidental or consequential loss. This limited warranty applies to product purchased in the U.S. and Canada.

Keep this Instruction Manual for future reference.

Keep your original proof of purchase (store receipt).

If parts are missing, DO NOT return to the store.

To order missing / replacement parts or for assembly assistance please contact customer_relations@atlantic-inc.com.

Or call 1-800-747-2660 M-F, 8am-5pm, P.S.T.

ATLANTIC

Manufactured under U.S. patents: 5,101,972 & 5,338,108
& 5,476,172. / Other U.S. and foreign patents pending.
©2010 Atlantic Inc. Santa Fe Springs, CA. U.S.A.
All rights reserved

www.atlantic-inc.com

Find the right disc, right now.
DISC Manager
Instructions

5.5 in